

FMTS

Optical Transceiver Tester

FMTS is the first instrument on the market, that is capable of full and complete all-parameters characterization of active optical components, especially for optical transceiver testing.

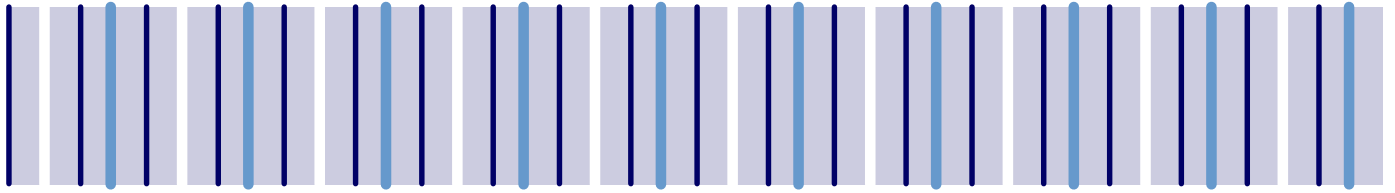



Product highlights

All-Parameter analysis – Complete spectral characterization of active optical device parameters.

Reduced measurement time – Eliminates manufacturing bottlenecks and reduces labor cost by providing comprehensive component characterization over 16 pieces in less than 5 minutes (~20 sec/1pcs 155M, 1X9 type in FMTS200/ATS). Equivalent testing using currently available equipment takes longer than 5 minutes/1pcs.

Capital investment reduction – Provides comprehensive analysis in a stand alone instrument. There is no need to have multiple, expensive instruments for complete analysis.

Minimal setup time – Automatic program control and determination of principal states.

Easy-to-use interface – Fully automated, requiring no special skills to operate. It can be easily integrated into a manufacturing production line.

Applications

Optical transceiver assembly and manufacturing

Quality assurance and regression testing

Production engineering and failure analysis

Incoming inspection and product qualification

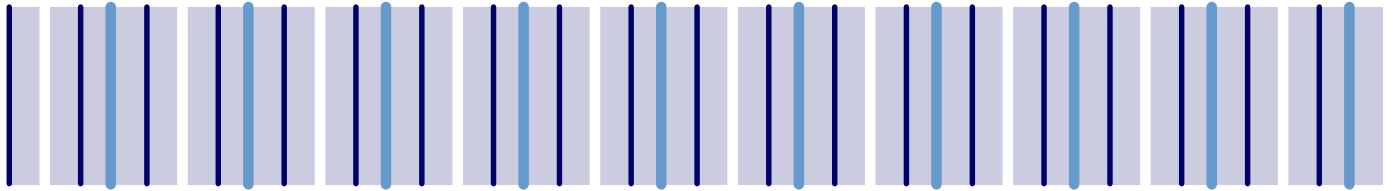

Faztec Optronics FMTS/ATS is the first instrument on the market, that is capable of full and complete all-parameter characterization of active optical components. The Faztec FMTS/ATS provides comprehensive component characterization of fiber optical transceiver in different standard, including SONET/SDH, GbE, Fiber Channel, even in different assembling type..1X9, SFF, SFP & GBIC. The FMTS/ATS can simultaneously perform 16 pieces (Maximum) optical active component characterizations in less than 5 min.

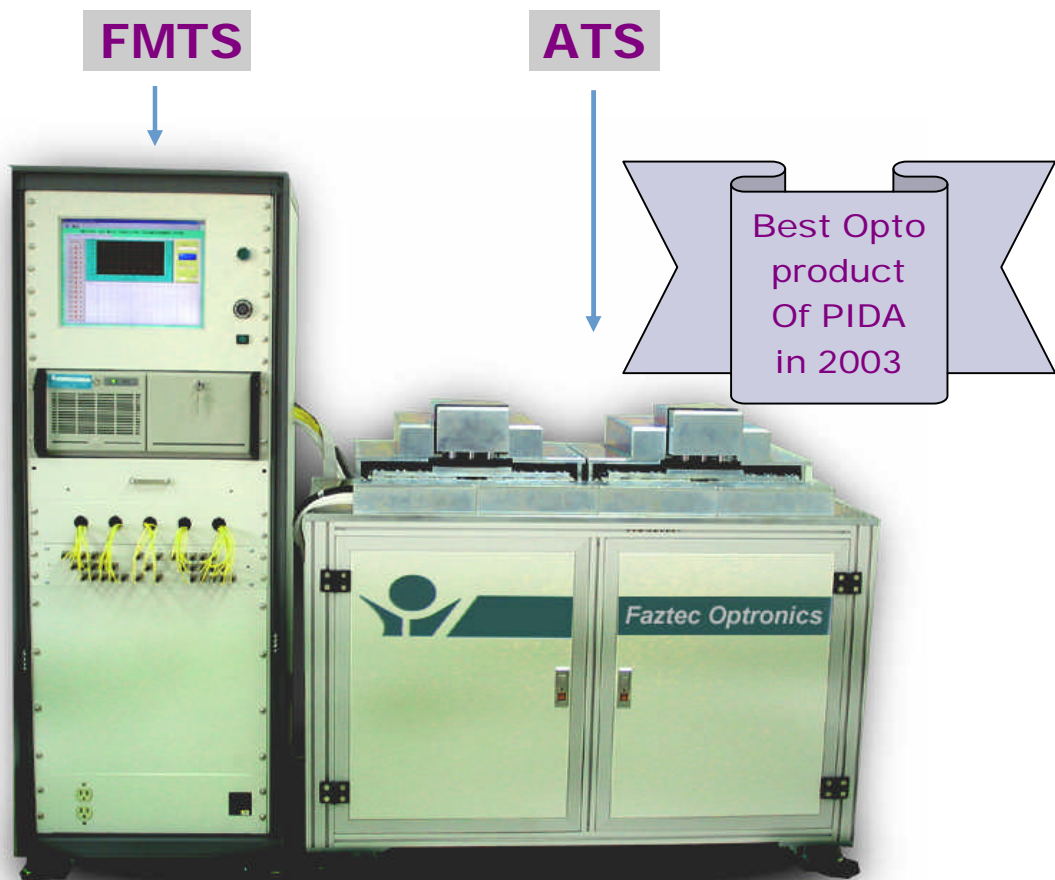



ATS (Fixture)

ATS assist FMTS To increase testing speed. Through ATS, customer can easy to load/unload DUT without manual handling. Further more, the progress include fiber plug/unplug after DUT loaded into Fixture. The application can fit to 1X9, SFF, SPB & GBIC different type of OE transceiver.

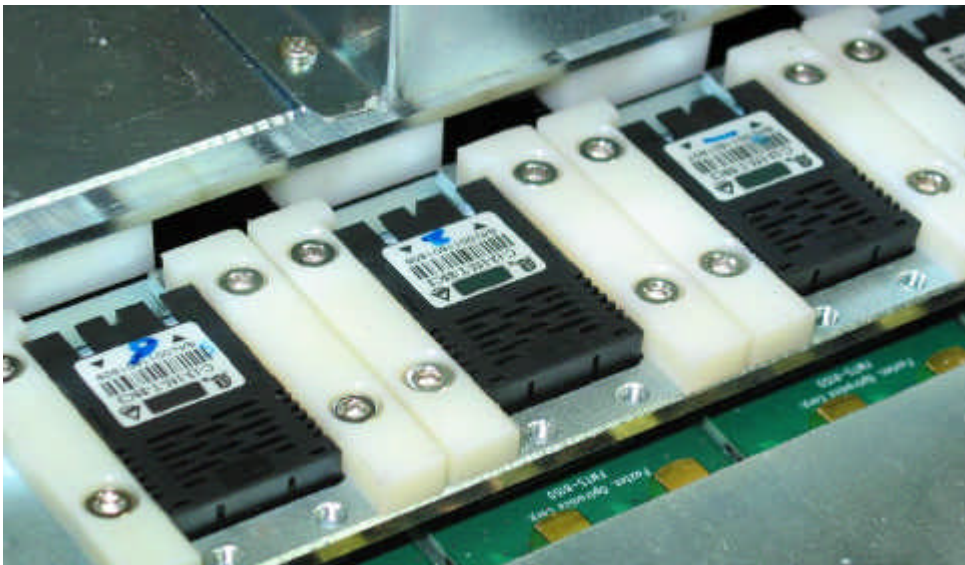

Automatic ATS

ATS is a rigid fixture for mass production transceiver used. Customer can select semi-auto or fully-auto ATS to support your FMTS. Standard option from 1ch to maximum 16chs. In ATS, you can also depend your requirement to add specific function, such as Bar-code label, IC Coding...et al.

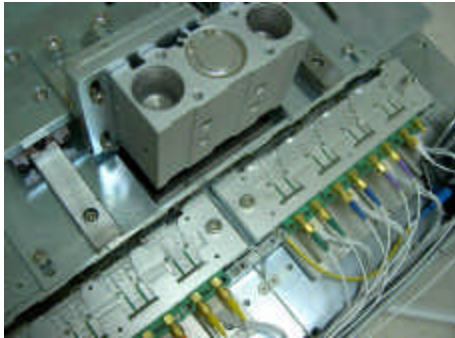

This Figure shows the construction of ATS, you can see the cables, EV board & semi-auto mechanism very clearly. Customer can easy operate & maintain the system & fiber.

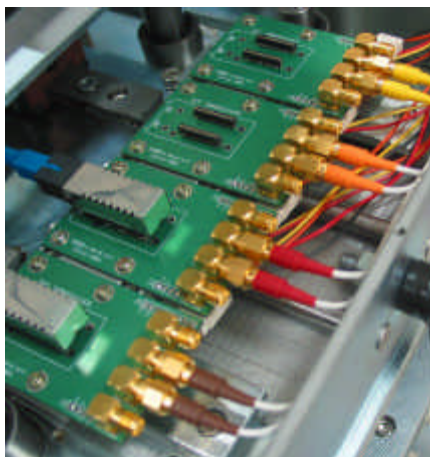

This Figure shows the exterior of EV board. Faztec can provide different type of EV board (1X9, SFF,SFP,GBIC/ data rate up to 3Gbps). If necessary, Faztec can also support special spec, such as Transponder or MUX/ DEMUX testing with high speed data rate (up to 10G).



This is manual testing for 1 channel DUT used. Customer can use this tool to modify your module in RD bench or in final OC testing.

FMTS system Architecture

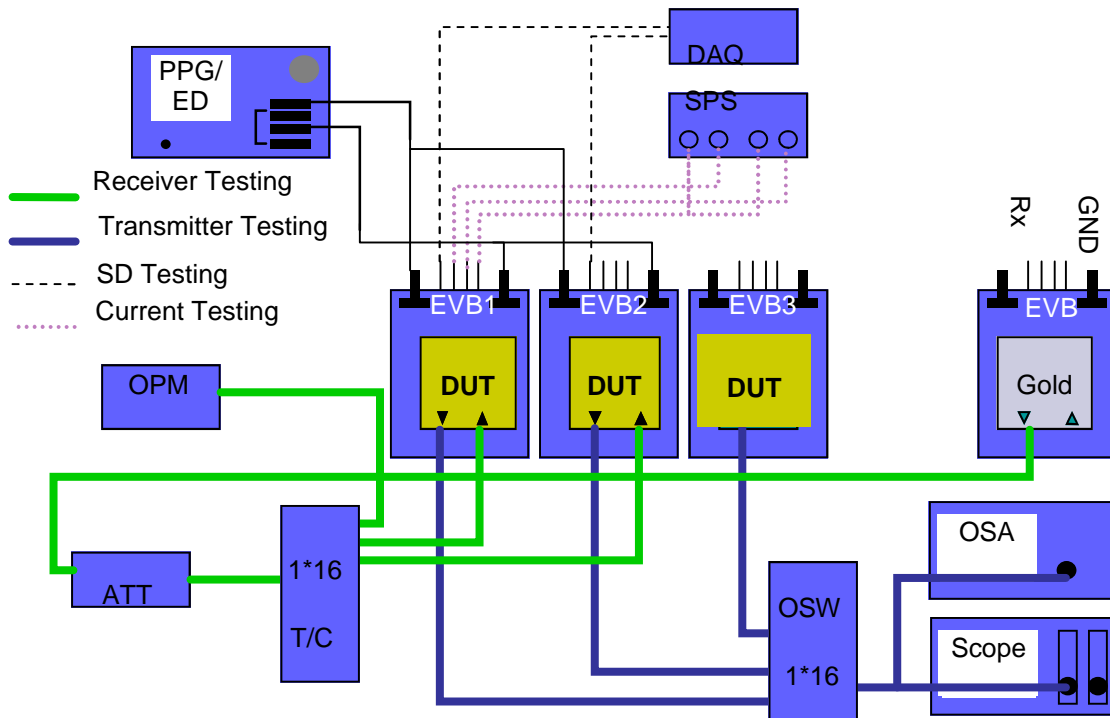

FMTS scheme is based on BERT (Bit Error Rate Tester), high speed sampling scope & optical power, Optical spectrum measuring technologies to maintain the stability & reliability of optical transceiver measurement.

In order to increase measurement speed & reduce measurement cost, Faztec also applies RF distributor, RF switch, RF power amplifier, phase shifter, optical switch, optical splitter into switch matrix system (FMS) of FMTS.

In measurement algorithm, FMTS reorganizes the transmitter & receiver measurement items to minimum measurement duration. For example, traditional 155M, 1X9, SM transceiver measurement needs at least 5 minutes to measure all parameters, but by FMTS/ATS, it just needs ~20 seconds to get the result.



FMTS Measurement Items

Transceiver	Receiver
Average Launch Power (dBm)	Sensitivity (BER, dBm)
Jitter (p-p, ps)	SD Asserted (dBm)
Extinction Ratio (dB)	SD Deasserted (dBm)
Rise Time / Fall Time (ns)	SD Hysteresis (dB)
Center Wavelength (nm)	SD Output Voltage - High (v)
Spectral Bandwidth (nm, RMS)	SD Output Voltage - Low (v)
Operating current (mA, 5VDC)	Operating Current (mA, 5VDC)
Eye width/ Mask Test (GO/NG)	SD Response Time (ns) H2L (Opt.)
DJ/RJ,TJ (FMTS1500/3000,Opt.)	SD Response Time (ns) L2H (Opt.)
Q Factor (FMTS1500/3000, Opt.)	

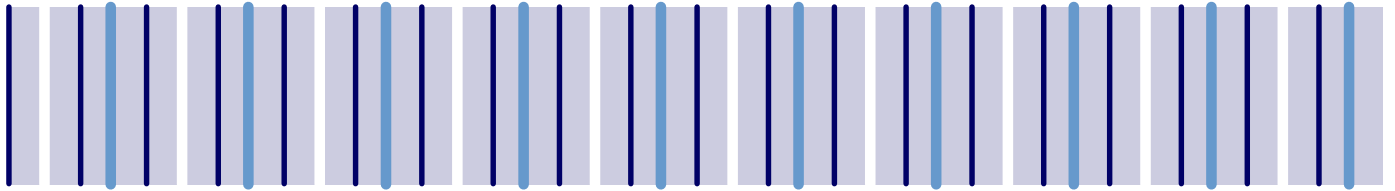

FMTS Waveform Performance

Pulse Pattern Generator

- Operation Frequency: 50Mbps~to 3.3Gbps (FMTS3000)
- Pattern : PRBS7,9,10,11,15,23,31
- Data Output Amplitude: -0.5V~+2V, Differential out put
- Offset Voltage: -2V~+3V
- Rise/Fall Time: Typically 80ps (at least 4.5GHz Bandwidth)
- Pattern Jitter: <30ps
- Output termination: ECL, PECL, CML, SCFL, LVPECL
- Trigger Mode: 1/8 clock, Pattern Sync.

Error Detector (Option)

- Operation Frequency: 50Mbps~3.3Gbps
- Input wave form: NRZ, Single-end Input
- Receive Pattern: PRBS7,9,10,11,15,23,31
- Data input amplitude: 0.5V to 2V
- Offset Voltage: -4V~+4V(VTH)
- Error rate: 1×10^{-16} to 1
- Auto Search Function: Phase & threshold

Synthesizer (Option)

- 50MHz~3.3GHz
- 1KHz step interval
- SSB: <-85dBc/Hz

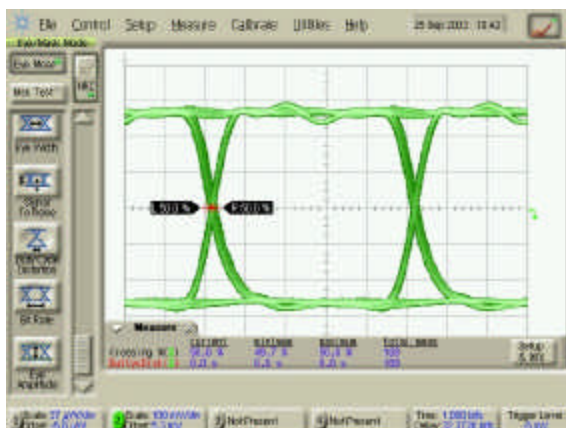

2.5Gbps, PRBS15

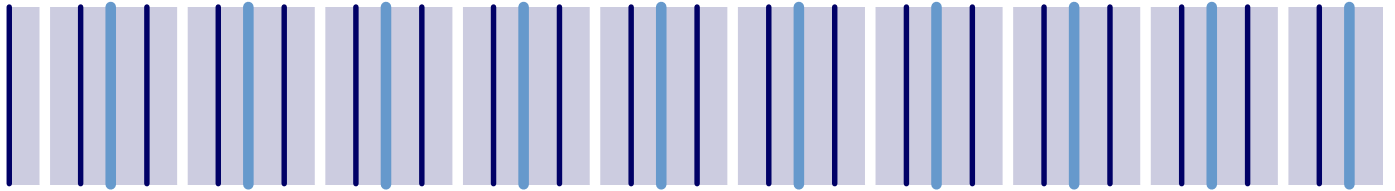

Waveform Analysis

Multimode OPTICAL CHANNEL SPECIFICATIONS

Optical Channel Unfiltered Bandwidth 3 GHz

Wavelength Range 750–860 nm

Calibrated Wavelengths 850 nm

Optical Sensitivity -17 dBm

Filter Bank 155M/622M/1063M/1250M/2125M/2488M (Option)

Transition Time Unfiltered 160ps

RMS Noise Characteristic 1.5 μ W Maximum 2.5 μ W

Average Power Monitor (specified operating range) -30 dBm to -2.2 dBm

User Calibrated Accuracy $\pm 2\%$ ± 100 nW \pm power meter uncertainty, $< 5^\circ$ C change

Maximum Input Power

Maximum non-destruct average 0.4 mW (-4 dBm)

Maximum non-destruct peak 10 mW ($+10$ dBm)

Fiber Input 62.5/125 μ m, user selectable connector

Input Return Loss (HMS-10 connector fully filled fiber) 20 dB

Single-Mode OPTICAL CHANNEL SPECIFICATIONS

Optical Channel Unfiltered Bandwidth 3 GHz

Wavelength Range 1000–1600 nm

Calibrated Wavelengths 1310 nm/1550 nm

Optical Sensitivity -20 dBm

Filter Bank 155M/1250M/2488M (Option)

Transition Time (10% to 90% calculated from $TR = 0.48/BW$ optical) 160 ps

RMS Noise Characteristic 0.75 μ W Opt 201 2 μ W 5 μ , (10 GHz Maximum 1.5 μ W)

Scale Factor (per division) Minimum 5 μ W 20 μ W

Factory Calibrated Accuracy

Single mode $\pm 5\%$ ± 100 nW \pm connector uncertainty (20° C to 30° C)

Maximum Input Power Maximum non-destruct average 0.4 mW (-4 dBm)

Fiber Input 62.5/125 μ m user selectable connector

Input Return Loss (HMS-10 connector fully filled fiber) 20 dB

OC-48 with filter waveform

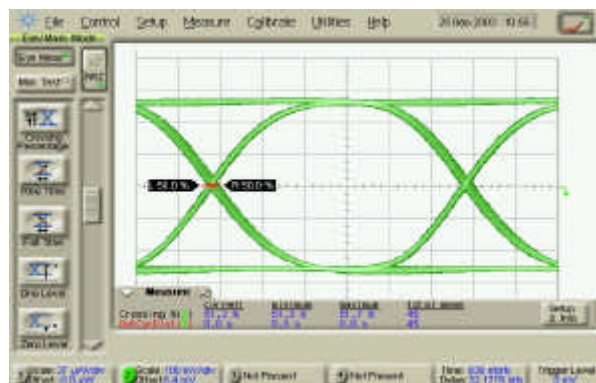

86105A 20GHz(E) + 12.5G O/E

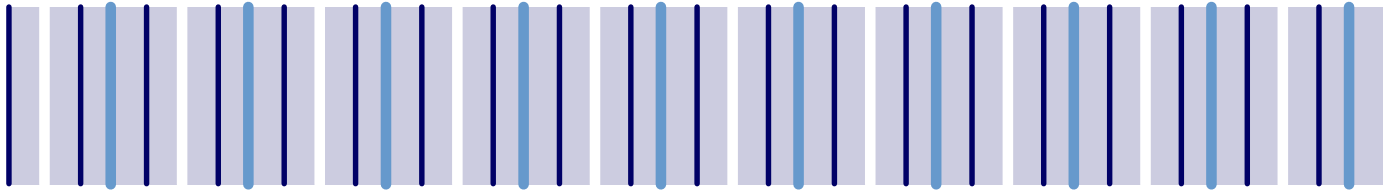

Big amount time saving compare with traditional Technique

FMTS using intelligent expertise evaluation software to save measurement time

Method	1 PC	4 PCS	Remarks
Traditional transceiver testing	~5 Min.	~15 Min.	Measurement time save 80% Production capacity increase 5 times
Faztec FMTS200/ATS	~20 Sec.	~5Min. (16pcs)	
Faztec FMTS3000/ATS	~1 Min.	~3Min.	

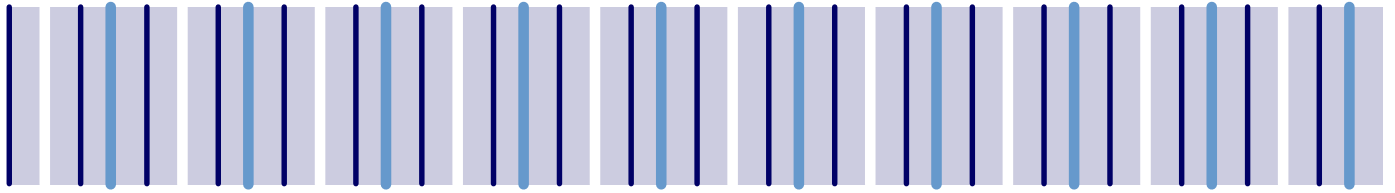

Target market map

SONET/SDH	OC-3	OC-12	OC-48
Ethernet	100M	1.25G	2.5G 3.125G
Fiber Channel	106M	1.0625G	2.125G
High Speed Drive	Toslink	USB2.0 IEEE1394	Rapid I/O



FMTS 200



FMTS 1500



FMTS 3000

SOFTWARE FEATURES

The Faztec Optronics FMTS/ATS software uses the statistics extrapolation method to compute , and uses R-square method to ascertain the data.

Faztec Optronics FMTS/ATS software is easy to use, with mouse controls and options easily accessible form main window or the menu bar.

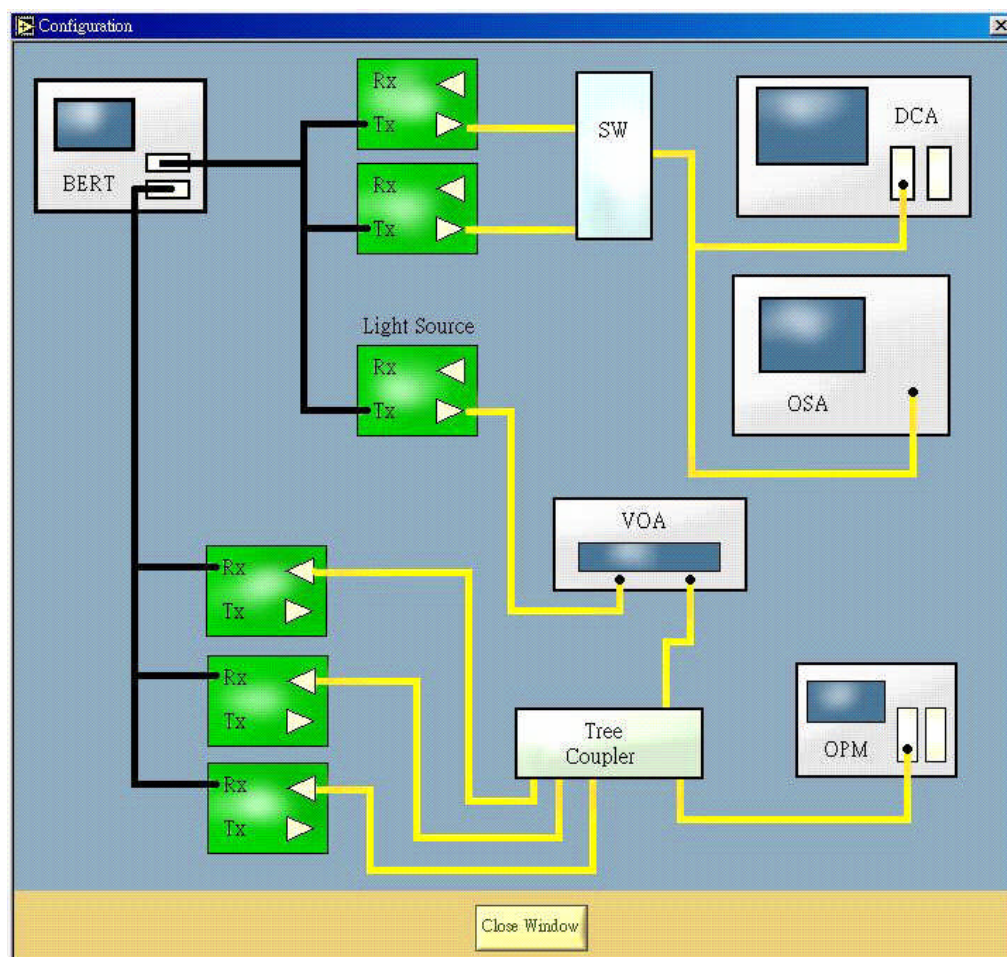

Calibration window feature

The Calibration window contains the value of different channel. It can provide clear and easy to understand screen. Every user can use without any problems.

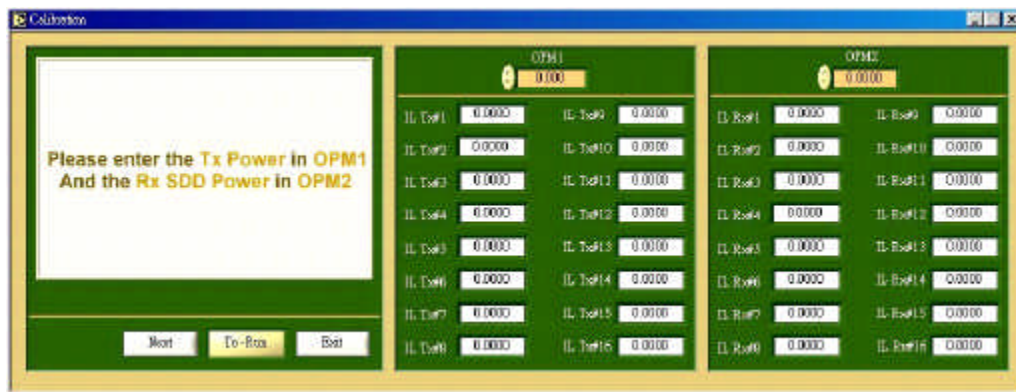

Setup window features

The Setup window provide user friendly environment.

User can load different setup data from disk or key in new value by hand.

User can setup different R-Square value to determine the measurement data.

User can setup different BER Sensitivity to calculate the minimum sensitivity.

User can setup different test item to fit customer's need.

The screenshot shows a software window titled "Setup" with two main sections: "CALIBRATION DATA" and "SPECIFICATION".

Load Calibration Data

TX Offset (dB)

1.95	2.07	1.89	1.77	1.55	1.67	1.90	1.82	1.48	1.24	1.20	1.54	1.80	1.79	1.56	1.90
------	------	------	------	------	------	------	------	------	------	------	------	------	------	------	------

Rx Offset (dB)

2.34	2.55	2.84	2.25	2.23	2.60	2.73	2.49	2.87	3.30	2.69	2.69	2.70	2.67	2.86	2.50
------	------	------	------	------	------	------	------	------	------	------	------	------	------	------	------

Load QC Spec.

Item	Check	LSL	USL	Unit
Output Power	<input checked="" type="checkbox"/>	1.00	-13.00	dBm
Extinction Ratio	<input checked="" type="checkbox"/>	1.00	10.00	dB
Txr. RMS	<input checked="" type="checkbox"/>	1.00	0.00	ps
Eye Width	<input checked="" type="checkbox"/>	1.00	5.00	ns
Mask Fail Count	<input checked="" type="checkbox"/>	1.00	0.00	number
Rx Sensitivity	<input checked="" type="checkbox"/>	1.00	-47.00	dBm
SD Dwell	<input checked="" type="checkbox"/>	1.00	-49.00	dBm
SD Hysteresis	<input checked="" type="checkbox"/>	1.00	1.00	dB
SD Assort	<input checked="" type="checkbox"/>	1.00	-49.00	dBm
SD High Voltage	<input checked="" type="checkbox"/>	1.00	-1.10	V
SD Low Voltage	<input checked="" type="checkbox"/>	1.00	-2.00	V
Carrier Wavelength	<input checked="" type="checkbox"/>	1.00	1280.00	nm
Spectral Bandwidth	<input checked="" type="checkbox"/>	1.00	0.00	nm
Tx Current	<input checked="" type="checkbox"/>	1.00	50.00	mA
Rx Current	<input checked="" type="checkbox"/>	1.00	50.00	mA

R-Square Limited: 0.80

BER Sensitivity: 1.00E-10

OK

Analysis window features

The Analysis window contains all measurement data in Excel format. Buttons on Parameters Select let you control which parameter you want to analysis in these DUTs.

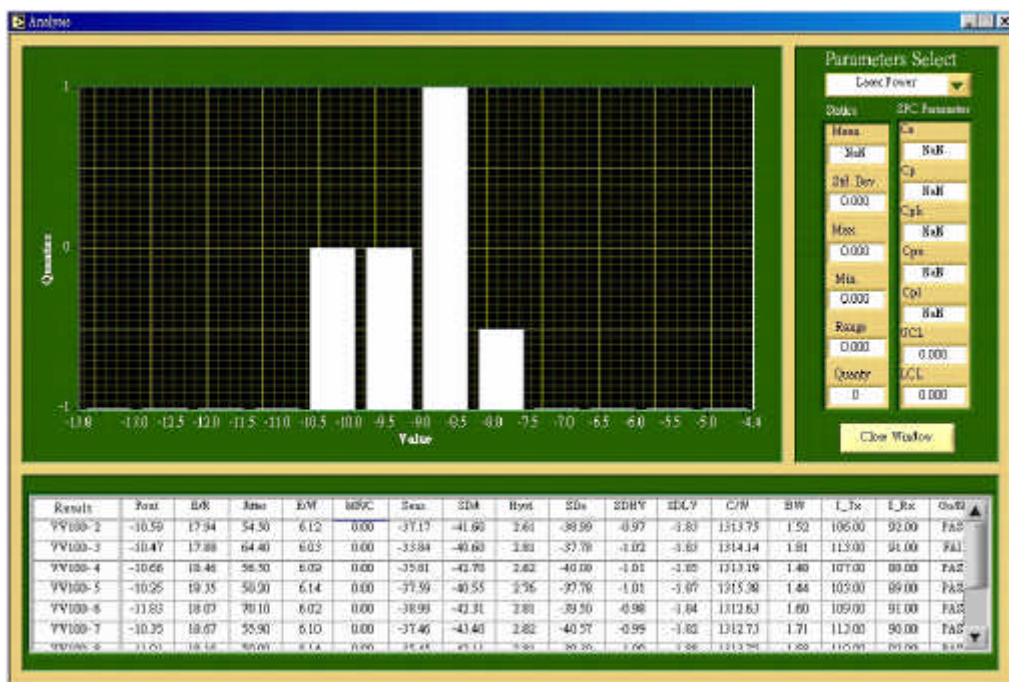

Final Report

All measurement parameter will show in Excel form to fit customer's need.

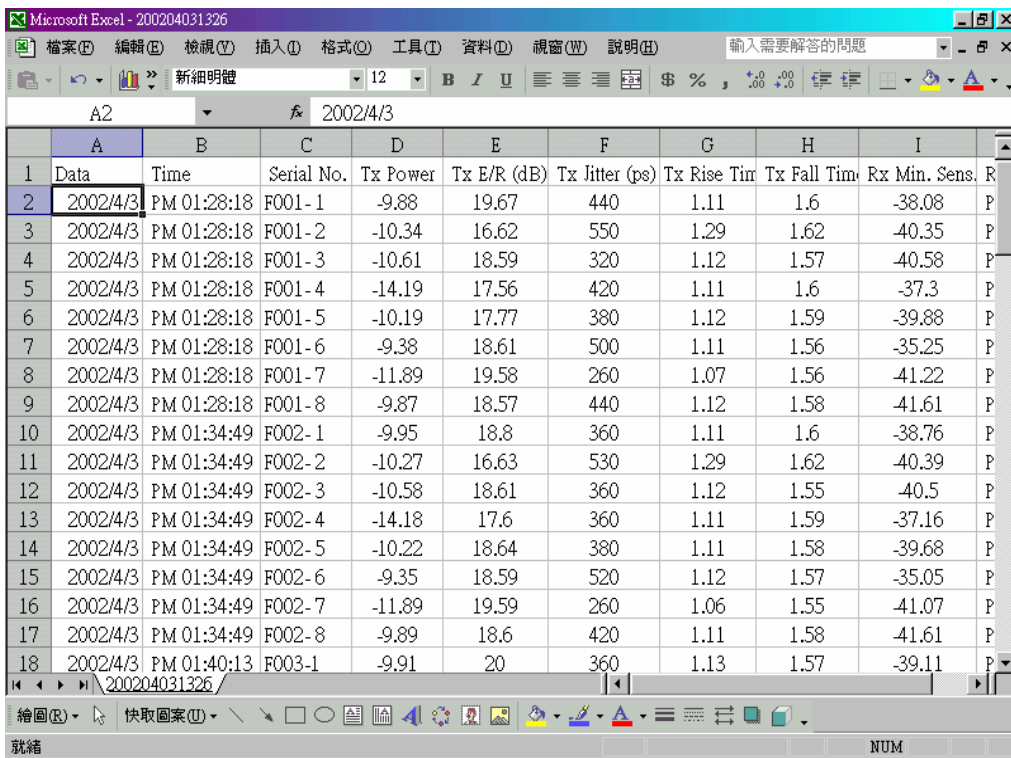

The screenshot shows a Microsoft Excel spreadsheet with the following data:

	A	B	C	D	E	F	G	H	I	J
1	Data	Time	Serial No.	Tx Power	Tx E/R (dB)	Tx Jitter (ps)	Tx Rise Tim	Tx Fall Tim	Rx Min. Sens.	R
2	2002/4/3	PM 01:28:18	F001-1	-9.88	19.67	440	1.11	1.6	-38.08	P
3	2002/4/3	PM 01:28:18	F001-2	-10.34	16.62	550	1.29	1.62	-40.35	P
4	2002/4/3	PM 01:28:18	F001-3	-10.61	18.59	320	1.12	1.57	-40.58	P
5	2002/4/3	PM 01:28:18	F001-4	-14.19	17.56	420	1.11	1.6	-37.3	P
6	2002/4/3	PM 01:28:18	F001-5	-10.19	17.77	380	1.12	1.59	-39.88	P
7	2002/4/3	PM 01:28:18	F001-6	-9.38	18.61	500	1.11	1.56	-35.25	P
8	2002/4/3	PM 01:28:18	F001-7	-11.89	19.58	260	1.07	1.56	-41.22	P
9	2002/4/3	PM 01:28:18	F001-8	-9.87	18.57	440	1.12	1.58	-41.61	P
10	2002/4/3	PM 01:34:49	F002-1	-9.95	18.8	360	1.11	1.6	-38.76	P
11	2002/4/3	PM 01:34:49	F002-2	-10.27	16.63	530	1.29	1.62	-40.39	P
12	2002/4/3	PM 01:34:49	F002-3	-10.58	18.61	360	1.12	1.55	-40.5	P
13	2002/4/3	PM 01:34:49	F002-4	-14.18	17.6	360	1.11	1.59	-37.16	P
14	2002/4/3	PM 01:34:49	F002-5	-10.22	18.64	380	1.11	1.58	-39.68	P
15	2002/4/3	PM 01:34:49	F002-6	-9.35	18.59	520	1.12	1.57	-35.05	P
16	2002/4/3	PM 01:34:49	F002-7	-11.89	19.59	260	1.06	1.55	-41.07	P
17	2002/4/3	PM 01:34:49	F002-8	-9.89	18.6	420	1.11	1.58	-41.61	P
18	2002/4/3	PM 01:40:13	F003-1	-9.91	20	360	1.13	1.57	-39.11	P

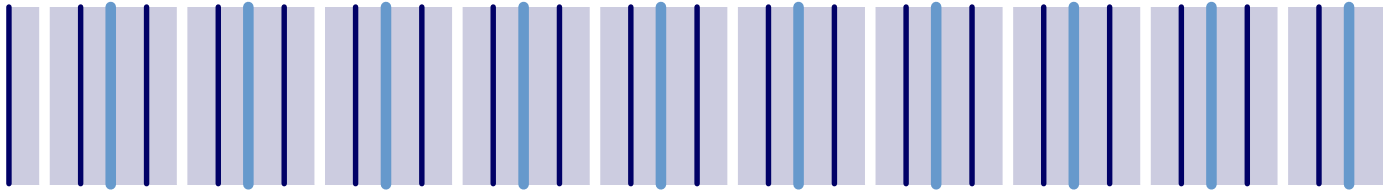

FMTS General Specification	
Max. Quantity	16 PCS
Measurement Timing	20~25secs/pcs (Typical, FMTS200) 30~40sec/pcs (Typical, FMTS1500) 1min/pcs(Typical, under FMTS3000)
Operating Temperature	15-30 ,Maximum variation range during a test 3
Operating Humidity	30-80%, Maximum variation range during a test 15% RH
Mechanical configuration	The equipment is installed in a single 19 inch rack with
Size	WxHxD = 560x1506.5x900 mm
Electrical Configuration	110 VAC , 60 HZ and 220 VAC, 50 HZ, 900 VA
Computer Configuration	PC using windows OS, NI GPIB controller board With programming software

ATS General Specification	
Bit Rate	UP to 3Gbps
Max. Quantity	4 chs(W/FMTS1500 & FMTS3000), 16chs(W/FMTS200)
Mechanical configuration	WxHxD = 1200x920x600 mm Weight >50 kg Working Plate : H= 820 mm
Operating Temperature	15-30 ,Maximum variation range during a test 3
Operating Humidity	30-80%, Maximum variation range during a test 15% RH
Electrical	110 VAC , 60 HZ and 220 VAC, 50 HZ, 900 VA
Air	>5 Kg/cm ²
Material	SS41, Zinc plated



FMTS200 Order Information

FMTS200

Option No.	Description	Note
EN	100 base/125M	
OC3	OC3/155M	
SM	Single Mode Type	
MM	Multi Mode Type	
4CH	4Chs O/E transceiver testing	Minimum 4Chs
8CH	8Chs O/E transceiver testing	
16CH	16Chs O/E transceiver testing	

Evaluation Board

Option No.	Description	Note
S1	1x9 Type	Minimum 4 PCS
S2	SFF Type	Minimum 4 PCS
P1	SFP Type	Minimum 4 PCS
BD	Bi-direction Type	Minimum 4 PCS

ATS (Fixture)

Option No.	Description	Note
SA	Semi-auto fixture	
FA	Fully-auto fixture W/handler	
4CH	4Chs fixture	Minimum 4Chs
8CH	8Chs fixture	
16CH	16Chs fixture	

Warranty

Option No.	Description
EW	Extend 2 yrs warranty

FMTS1500 Order Information

FMTS1500

Option No.	Description	Note
EN	100 base/125M	
EG	GbE/1.25G	
OC3	OC3/155M	
OC12	OC12/622M	
FC	Fiber channel/1.0625G	
SM	Single Mode Type	
MM	Multi Mode Type	
1CH	1Chs O/E transceiver testing	Minimum 1Chs
2CH	2Chs O/E transceiver testing	
4CH	4Chs O/E transceiver testing	

Evaluation Board

Option No.	Description	Note
S1	1x9 Type	Minimum 2 PCS
S2	SFF Type	Minimum 2 PCS
P1	SFP Type	Minimum 2 PCS
P2	GBIC Type	Minimum 2 PCS
BD	Bi-direction Type	Minimum 2 PCS

ATS (Fixture)

Option No.	Description	Note
SA	Semi-auto fixture	
FA	Fully-auto fixture W/handler	
1CH	1Chs fixture	Minimum 1Chs
2CH	2Chs fixture	
4CH	4Chs fixture	

Warranty

Option No.	Description
EW	Extend 2 yrs warranty



FMTS3000 Order Information

FMTS3000

Option No.	Description	Note
EN	100 base/125M	
EG	GbE/1.25G	
EGT	10GbE/3.125G	
OC3	OC3/155M	
OC12	OC12/622M	
OC48	OC48/2.5G	
FC	Fiber channel/1.0625G	
FC2	2XFiber channel/2.125G	
SM	Single Mode Type	
MM	Multi Mode Type	
1CH	1Chs O/E transceiver testing	Minimum 1Chs
2CH	2Chs O/E transceiver testing	
4CH	4Chs O/E transceiver testing	

Evaluation Board

Option No.	Description	Note
S1	1x9 Type	Minimum 2 PCS
S2	SFF Type	Minimum 2 PCS
P1	SFP Type	Minimum 2 PCS
P2	GBIC Type	Minimum 2 PCS
BD	Bi-direction Type	Minimum 2 PCS

ATS (Fixture)

Option No.	Description	Note
SA	Semi-auto fixture	
FA	Fully-auto fixture W/handler	
1CH	1Chs fixture	Minimum 1Chs
2CH	2Chs fixture	
4CH	4Chs fixture	

Warranty

Option No.	Description
EW	Extend 2 yrs warranty

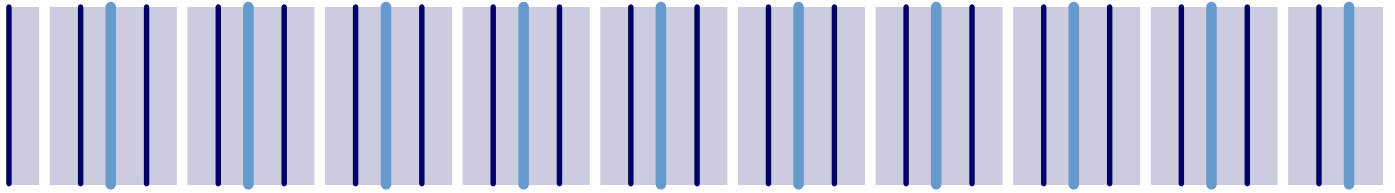

WARRANTY

All equipment is fully warranted for one year. This includes hardware repair or replacement, at customer site or Faztec factory, and software Updates.

All specification are subject to change without notice



TEL: 886-3-4698288
FAX: 886-3-4698286
www.faztec.com.tw
sales@faztec.com.tw

1, Kong-Yeh 11 Rd, Ping Jen Industrial Area, Tao Yuan, Taiwan